

**MSA<sup>®</sup>**

*member of RKL HOLDING*

**BALL VALVES**



# Content

Design	4
Design Details	6
Accessories	8
Quality system	10
Certification	11
Research and Development	11
Manufacturing Program	12

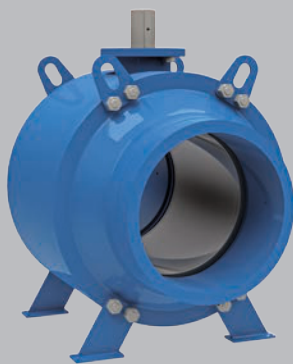

K 83 TW

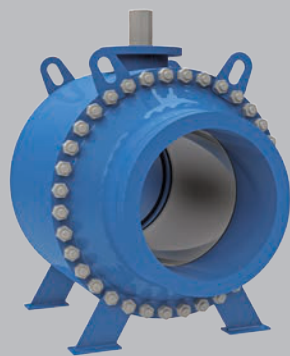

K 83 TB

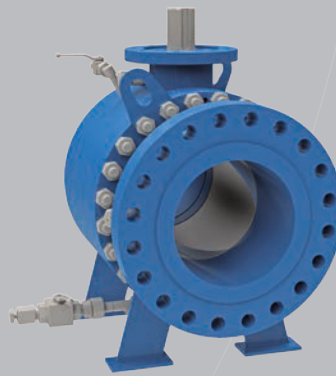

K 83.9



K 83.8

# Ball Valve Design

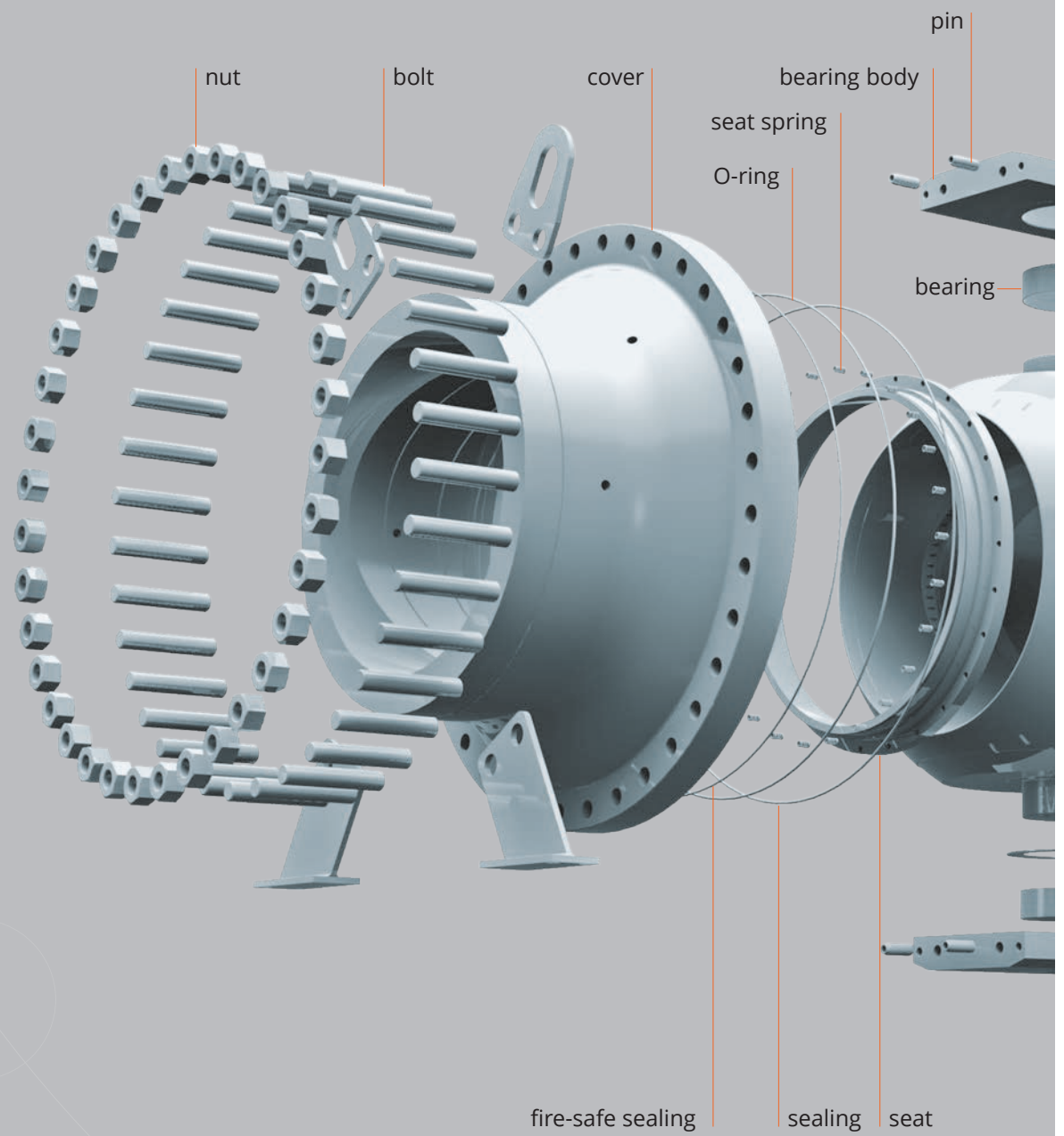

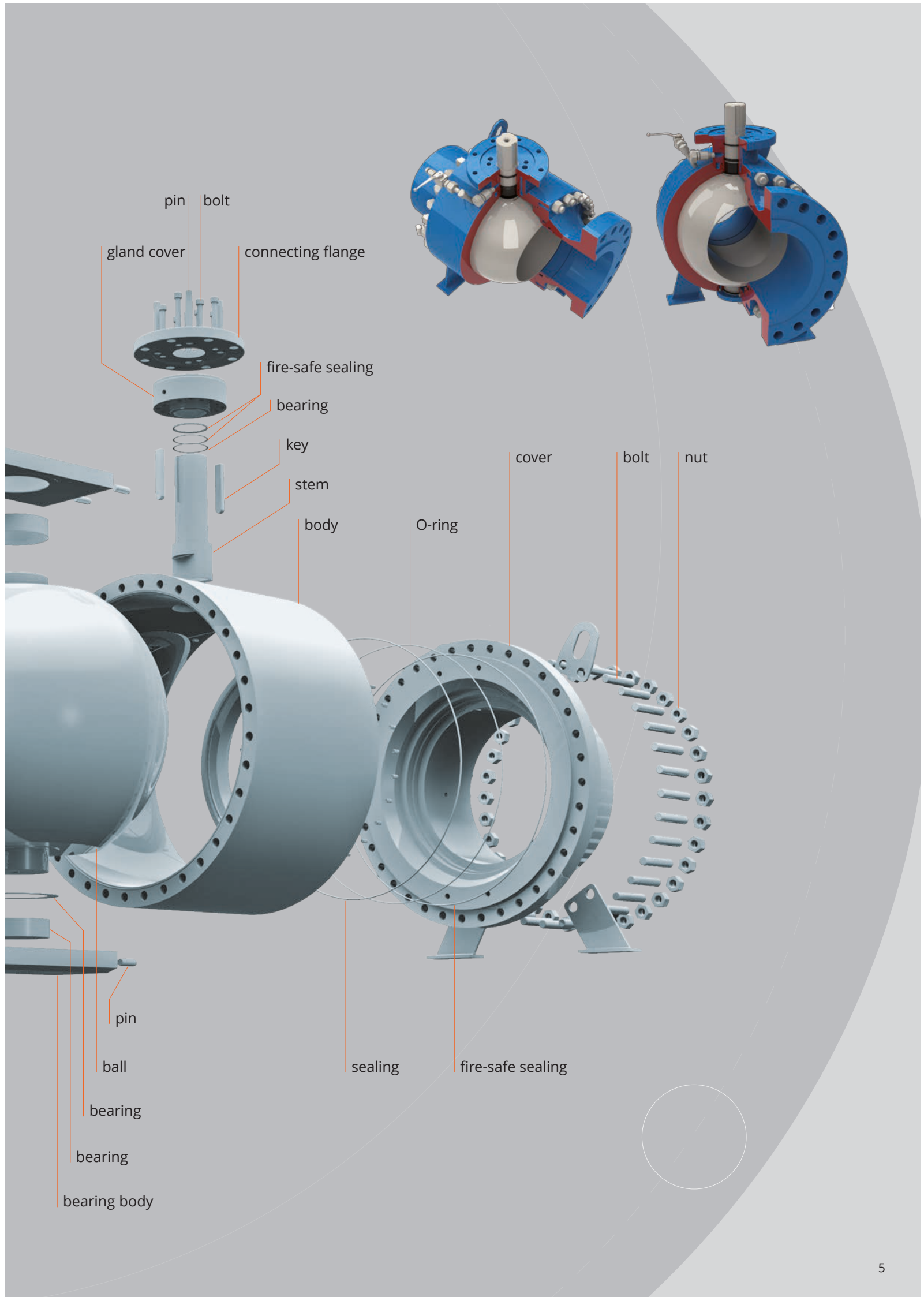

# Design Details

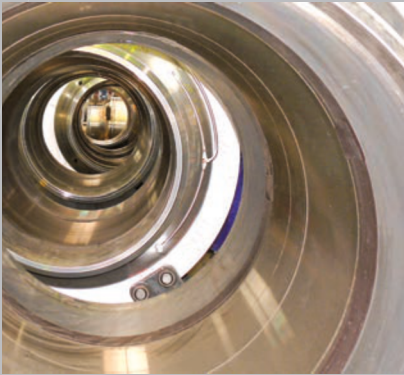

## Body

Ball valve body is made of three forgings, where the individual parts are bolted or welded together. Body dimensions are chosen to meet not only strength and rigidity requirements of corresponding standards, but also to be able to transfer external forces and torques from pipeline.



## Ball

Ball of a ball valve is trunnion mounted and made of a single-piece shaped semifinished product. Surface of ball could be covered according to working medium with layer of Cr or Ni, overlay of hard metal or tungsten carbide coating.

## Seat

Seats are designed as PMSS (primary metal secondary soft) or in metal-to-metal configuration without a soft sealing element. In PMSS seats, an elastomer (HNBR, VITON, etc.) or a plastomer (RPTFE, PEEK, PCTFE, etc.) is used as the soft sealing material, depending on the service fluid.

It is possible to use sealing paste on both types of seats also in fireproof design.

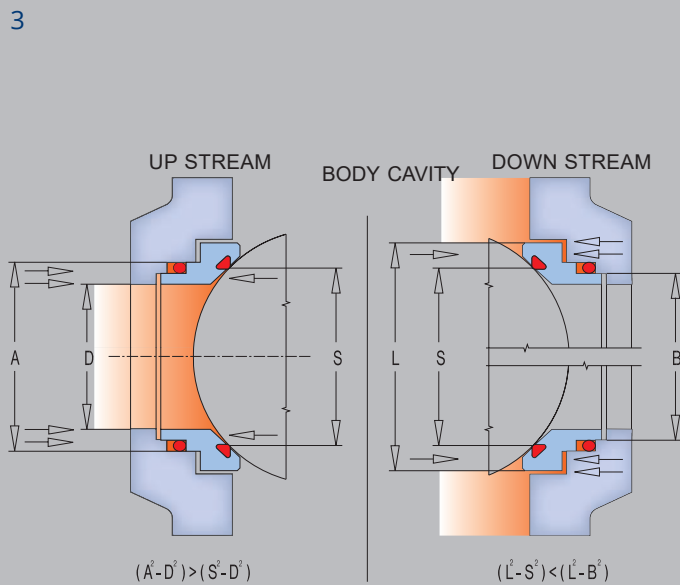
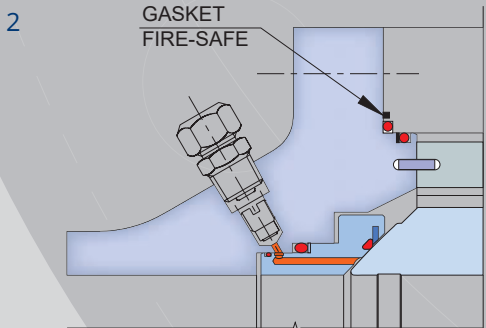
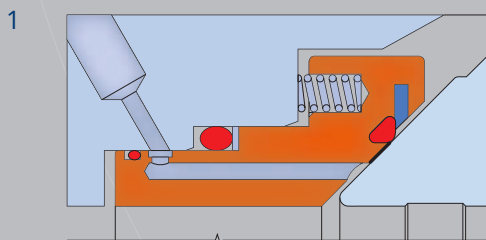

# Design solution for long service life and reliability

Sealing paste, which can be injected between seat and ball, can be used as tertiary sealing (Pict. No. 2). For gas media it is recommended to use seats in DPE design (Double Piston Effect) (Pict. No. 3). DPE design means, that if upstream seat is damaged, function of a ball valve is still secured by a downstream seat. SPE (Single Piston Effect) self-relieving seats are used for liquid media, which enable relief of excess pressure from body cavity to pipeline.

## Stem (Pict. No. 4)

Stem is of anti blow-out design so it cannot be ejected of a body due to improper handling. Stem is sealed by three independent sealing rings. Stem can be also sealed by sealing paste when leaking. Last sealing ring can be replaced at full service pressure without danger of ejecting stem. The forces acting on the trunnion are alternatively absorbed by bearing plates or by bearings housed within the body. The

design department selects the appropriate alternative based on the application and service conditions.

## Antistatic design

All internal metal components are conductively connected with ball valve body. This is preventing the ball from electrostatic charging.

## Double Block and Bleed (DBB) (Pict. No. 5)

All ball valves are supplied with DBB feature, which means that it is possible to bleed the body in fully closed or fully opened position.

## Lubrication

Forces arising due to pressure acting on a ball are caught by self-lubricating bearings with low friction coefficient. Thus the ball valves have low torque and do not require any maintenance.

## External Leakage

Theoretical areas of external leakage are body-bonnet joints and trunnion. These parts are therefore designed to meet requirements for low emission valves.

## Position Adjustment (Pict. No. 6)

Every ball valve, which is supplied without actuator (bare stem), is equipped with a special device, by which it is very easy to adjust ball position. Due to this feature it is possible to perform installation or removal of actuator on ball valves also after their installation into pipeline.

## Fire-Safe Design

MSA ball valves are fire-tested for the whole manufacture range according to API 607, API 6FA and BS 6755, part 2 standards. Fire-safe certificate was issued by an independent international organization.

4

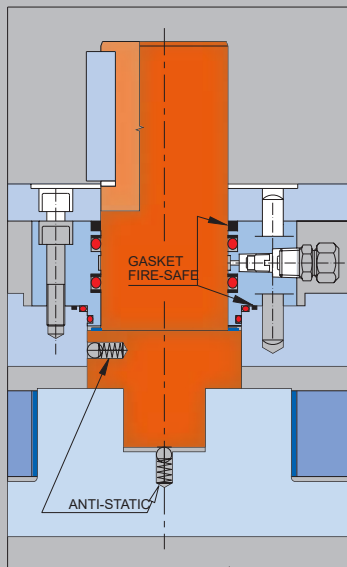

5

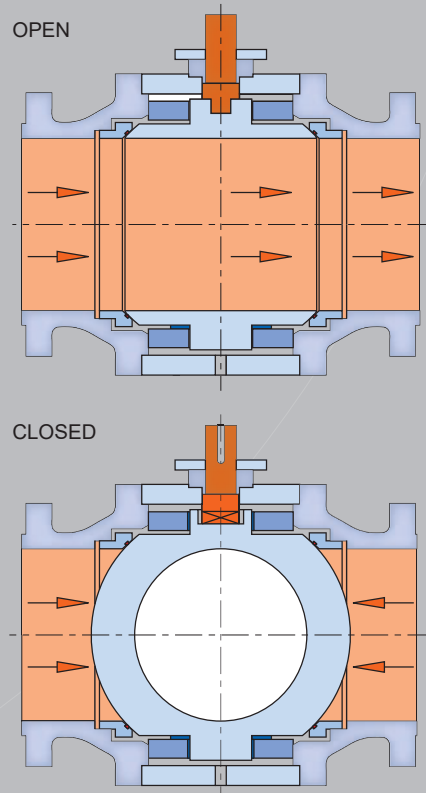

6

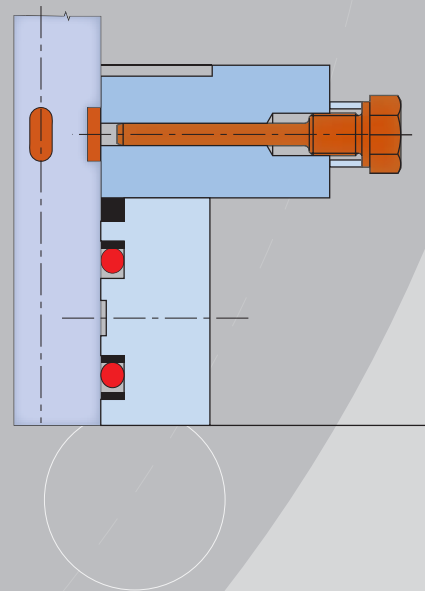

# Accessories

## Stem extension (Pict. No. 7)

Stem extension and length of stem extension is available based on customer's request, namely for underground ball valves (see picture).

## Accessories (Pict. No. 8)

MSA furnishes ball valves with further accessories depending on customer's requirements, such as drain, vent, grease fittings, power supply to actuators, pressure relief valves etc. Sealant injection lines are terminated by two independent grease fittings. Drain and vent pipes, actuator supplies are terminated by ball valves.

Pressure reduction in ball valve body In case that service conditions enable increase of pressure in body cavity higher than nominal pressure, ball valve must be ordered with a device for pressure reduction. This is enabled either by seat modification or by a relief outside the ball valve. When relieving pressure through seat, DPE function is cancelled.

## Pups (Pict. No. 9)

MSA ball valves with butt-weld ends do not require any pup pieces if operating and installation instructions are observed. However, if pup pieces are required, MSA supplies pup pieces in two possible options:

**Option A:** Pup piece is a forging, which is welded to basic material before final machining. Ball valve is assembled together with the pup piece.

**Option B:** Pup piece is part of pipe of the same grade and dimensions as pipeline. Ball valve is manufactured and tested with standard dimensions and then pup piece is welded and checked. Pup piece length is not limited for this option, except for transport reasons. However, if pipe of nonstandard grade or sizes is used, it is recommended that the customer supplies the pup material.

7

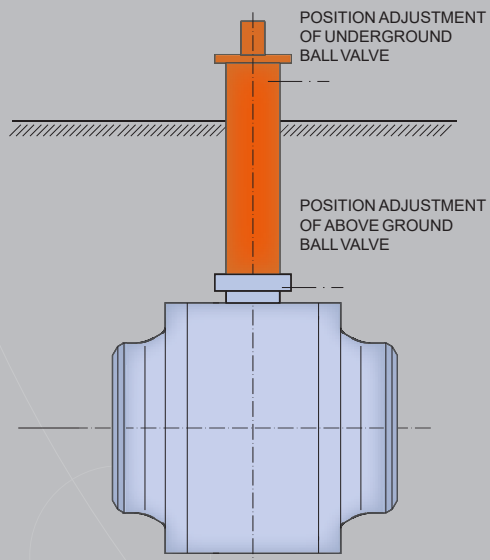

8

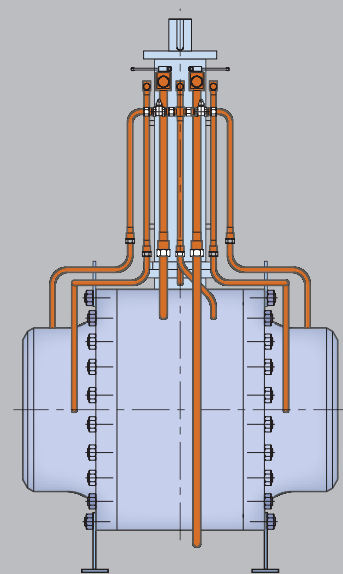

# Design solution for long service life and reliability

## Actuators

Ball valve operation can be manual, electric, pneumatic, hydraulic, hydropneumatic or electropneumatic type. MSA cooperates with all leading actuator manufactures.

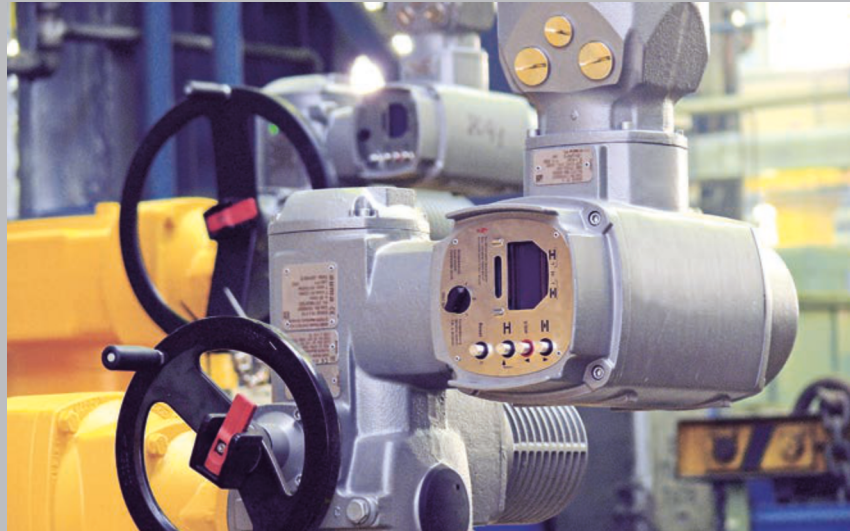

9

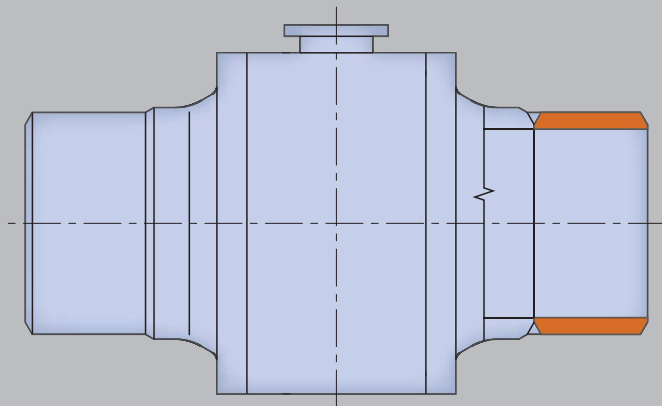

# Quality System

Whole manufacturing process of ball valves is thoroughly monitored and includes the following tests and inspections: receiving inspection of all raw materials and sub-supplies, in-process inspection during manufacture of individual parts, assembly tests, pressure tests, functional tests, nondestructive tests, final inspection of finished products.

## Pressure tests

All pressure tests are performed in accordance with API 598, API 6D/ ISO 14313, DIN 3230, EN 12266, ISO 5208 and ANSI/FCI 70-2. MSA also performs special tests according to API 6D, e.g. low-pressure air tests, DBB and DPE tests. All tests are performed by full operating pressure as a standard. MSA also respects special specification requirements of customer.

## Special tests

MSA performs many special tests, by which we verify properties of our ball valves. All tests are witnessed by independent test institutes. The following tests were performed on MSA ball valves:

**Fire test** – according to API 6FA, API 607 and BS 6755, part 2, for Class 150, 300, 600 and 900

**Tightness and functional test** – at temperature from  $-60\text{ }^{\circ}\text{C}$  to  $+200\text{ }^{\circ}\text{C}$

**Cycle tests** – according to EN 14141, annexes C and D

**Hydrodynamics and aerodynamics test** – verification of hydro-pneumatic and aerodynamic properties is done by simulation measurement of torque value in dependence on ball opening angle.

## Non-destructive tests

MSA performs non-destructive tests in its own test rooms and equipment. Nondestructive tests include RT, MT, UT or DP tests. Personnel performing these tests is highly qualified and certified according to EN 473 or SNT-TC-1A.

## Functional tests

All ball valves are functionally tested with actuator. Torque value is verified during this test as well.

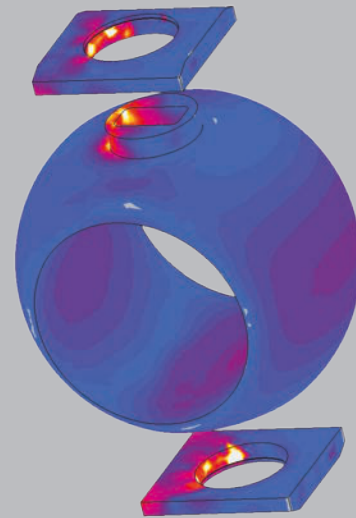

# Application of Standards

Quality system of standards MSA, a.s. is based on strict observance of norms EN ISO 9001:2008, EN ISO 14001:2004 and API Spec Q1 (Specification D - number 0239).

There are different standards used for design, production and testing of valves, based on customer's requirements, such as:

<b>ASME/ANSI</b>	B 16.5, B 16.10, B 16.25, B 16.34, B 16.37, ASME section V., VIII. and IX.
<b>API</b>	SPEC Q1, SPEC 6A, SPEC 6D, SPEC 5L, SPEC 6FA, std. 607, std. 598
<b>MSS</b>	SP 6, SP 25, SP 53, SP 54, SP 72
<b>BS</b>	1560, 2080, 5146, 5351, 6755 part 2
<b>ASTM</b>	material specifications of materials used
<b>ISO</b>	EN ISO 9001:2008, 5211m EN 10 204, NACE - MR-01-75
<b>DIN</b>	1690, 2505, 2544-48, 2526, 3203, 3230, 3840,
<b>EN</b>	EN 14141, EN 1092-1, EN 12266, EN 1262, EN 15848-1, EN 15848-2, EN 61508

# Research and Development

MSA Ball Valves cope with the most demanding requirements of customers'. MSA Ball Vaves are able to work in long-term service and are reliable in various climatic and service conditions. Designers attention during development and verification is focused on functionality and properties of new valves, mainly on these aspects:

- strength of material used
- design strength and rigidity (FEM method)
- reliability of valves under hydraulic and aerodynamic load

New products are tested both at MSA testing rooms, as well as under real service conditions.

Product properties are regularly monitored during its whole service life and findings are applied for development and manufacture of new products.



# K 83 TW

## Fully welded body ball valves

- Water, gas, oil, acid, hydraulic fluid, and hydrogen process medium
- Flanged or welded connection
- Range of working temperatures from -60 °C to +200 °C



### Standard Material Specification:

	part	standard design from -29 °C to 120 °C	low temperatures from -60 °C to 120 °C	sour working medium according to NACE MR-01-75 from -46 °C to 120 °C	high temperatures from -10 °C to 200 °C
1	body	ASTM A 350 LF2	ASTM A 350 LF2	ASTM A 350 LF2	ASTM A 350 LF2
2	cover	ASTM A 350 LF2, A 694 F52, A 694 F60	ASTM A 350 LF2, A 694 F52, A 694 F60	A 350 LF2, A 694 F52, A 694 F60	ASTM A 350 LF2, A 694 F60
3	ball	ASTM A 350 LF2 + Cr or Ni	ASTM A 350 LF2 + Cr or Ni	ASTM A 350 LF2 + Ni	ASTM A 350 LF2 + Cr or Ni
4	seat	ASTM A 350 LF2 + Ni	ASTM A 350 LF2 + Ni	ASTM A 350 LF2 + Ni or F316	ASTM A350 LF2 + Ni
5	trunnion, stem	ASTM A 350 LF2, AISI 4140 + Ni (Cr)	ASTM A 350 LF2, AISI 4140 + Ni (Cr)	ASTM A 350 LF2 + Ni, A 182 F316	ASTM A 350 LF2, AISI 4140 + Ni (Cr)
6	bolt	ASTM A 193 B7	ASTM A 320 L7 (M)	ASTM A 320 L7M	ASTM A 193 B7
7	nut	ASTM A 194 2H	ASTM A 194 Gr.7 (M)	ASTM A 194 7M	ASTM A 194 2H
8	flange	ASTM A 350LF2, S 355J2	ASTM A 350LF2, S 355J2	ASTM A 350LF2, S 355J2	ASTM A 350LF2, S 355J2
9	ball gasket	THERBAN, VITON, PTFE, NYLON, DEVLON, PEEK	THERBAN (LOW), PTFE, NYLON, DEVLON, PEEK	VITON, DEVLON, PTFE, NYLON, PEEK	VITON, PTFE, PEEK
10	gasket sealing ring	THERBAN, VITON	THERBAN (LOW)	VITON	VITON
11	KU bushing	CARBON STEEL + PTFE	CARBON STEEL + PTFE	STAINLESS STEEL + PTFE	CARBON STEEL + PTFE
12	axial bearing	CARBON STEEL + PTFE	CARBON STEEL + PTFE	STAINLESS STEEL + PTFE	CARBON STEEL + PTFE
13	gasket ring - fire safe	GRAPHITE	GRAPHITE	GRAPHITE	GRAPHITE
14	seat springs	AISI 302	AISI 302	INCONEL 750	AISI 302

- Other material specifications according to manufacturer's suggestion or customers' requirements.

PN 16 – Class 150

NPS	DN	D	L BW	L RF	L RTJ	Dv	E	F	weight (kg)	
									BW	RF, RTJ
2"	50	49	216	178	191	175	93	118	21	27
3"	80	74	283	203	216	200	108	133	40	45
4"	100	100	305	229	241	240	128	210	58	69
6"	150	152	457	394	406	330	231	245	145	170
8"	200	203	521	457	470	405	277	288	245	270
10"	250	254	559	533	546	479	310	331	320	354
12"	300	305	635	610	622	549	344	368	560	610
14"	350	337	762	686	699	598	370	393	860	925
16"	400	387	838	762	775	688	415	437	1 036	1 206
18"	450	438	914	864	876	760	453	470	1 320	1 540
20"	500	489	991	914	927	842	491	515	1 758	1 832
22"	550	540	1 067	991	1 003	930	545	560	2 150	2 350
24"	600	591	1 143	1 067	1 080	995	598	605	2 860	2 970
26"	650	635	1 245	1 143	-	1 045	622	632	3 420	3 650
28"	700	686	1 346	1 245	-	1 150	675	683	4 250	4 533
30"	750	737	1 397	1 295	-	1 226	713	721	5 000	5 307
32"	800	781	1 524	1 372	-	1 325	763	775	5 640	6 090
34"	850	822	1 626	1 473	-	1 415	808	840	6 420	6 870
36"	900	876	1 727	1 524	-	1 468	834	849	8 040	8 565
40"	1 000	978	1 780	1 850	-	1 616	928	943	10 260	10 872
42"	1 050	1 022	1 840	1 900	-	1 690	965	1 012	13 600	14 500
44"	1 100	1 075	1 900	1 950	-	1 782	1 010	1 026	14 800	15 850
48"	1 200	1 168	2 100	2 180	-	1 922	1 061	1 097	16 800	17 800
56"	1 400	1 362	2 250	2 300	-	2 250	1 232	1 268	25 720	27 205

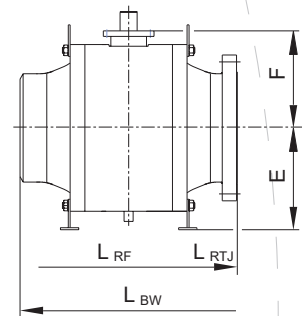

PN 40 (50) – Class 300

NPS	DN	D	L BW	L RF	L RTJ	Dv	E	F	weight (kg)	
									BW	RF, RTJ
2"	50	49	216	216	232	175	93	118	22	28
3"	80	74	283	283	298	210	113	133	41	55
4"	100	100	305	305	321	245	130	225	59	78
6"	150	152	457	403	419	330	231	245	145	178
8"	200	203	521	502	518	405	277	288	245	293
10"	250	254	559	568	584	479	310	331	320	392
12"	300	305	635	648	664	549	344	368	560	660
14"	350	337	762	762	778	598	370	393	860	990
16"	400	387	838	838	854	688	415	437	1 036	1 286
18"	450	438	914	914	930	760	453	470	1 320	1 640
20"	500	489	991	991	1 010	842	491	515	1 758	1 928
22"	550	540	1 092	1 092	1 114	930	545	560	2 190	2 450
24"	600	591	1 143	1 143	1 165	995	598	605	2 860	3 060
26"	650	635	1 245	1 245	1 270	1 045	622	632	3 500	3 820
28"	700	686	1 346	1 346	1 372	1 150	675	683	4 250	4 815
30"	750	737	1 397	1 397	1 422	1 226	713	721	5 000	5 595
32"	800	781	1 524	1 524	1 553	1 325	763	775	5 640	6 430
34"	850	822	1 626	1 626	1 654	1 415	808	840	6 420	7 050
36"	900	876	1 727	1 727	1 756	1 468	834	849	8 040	8 966
40"	1 000	978	1 780	1 850	-	1 616	928	943	10 260	10 890
42"	1 050	1 022	1 840	1 900	-	1 690	965	1 012	13 600	14 500
44"	1 100	1 075	1 900	1 950	-	1 782	1 010	1 026	14 800	16 050
48"	1 200	1 168	2 100	2 180	-	1 922	1 061	1 097	16 800	17 920
56"	1 400	1 362	2 250	2 300	-	2 250	1 232	1 268	25 720	27 310

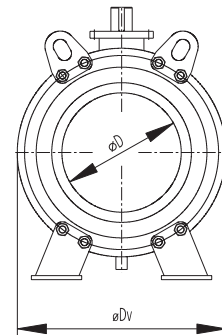

### PN 63 – Class 400

NPS	DN	D	L BW	L RF	L RTJ	Dv	E	F	weight (kg)	
									BW	RF, RTJ
2"	50	49	292	292	295	175	93	125	24	30
3"	80	74	356	356	359	220	113	148	50	68
4"	100	100	406	406	410	245	130	200	64	88
6"	150	152	495	495	498	330	237	249	148	198
8"	200	203	597	597	600	413	277	297	289	362
10"	250	254	673	673	676	488	314	337	404	522
12"	300	305	762	762	765	569	355	378	648	785
14"	350	337	826	826	829	621	381	400	908	1 072
16"	400	387	902	902	905	713	427	448	1 401	1 619
18"	450	438	978	978	981	775	460	492	1 650	1 810
20"	500	489	1 054	1 054	1 060	868	500	538	2 181	2 487
22"	550	540	1 143	1 143	1 153	956	558	583	2 510	2 830
24"	600	591	1 232	1 232	1 241	1 030	615	615	3 436	3 856
26"	650	635	1 308	1 308	1 321	1 080	640	650	3 860	4 320
28"	700	686	1 397	1 397	1 410	1 180	675	690	5 276	5 836
30"	750	737	1 524	1 524	1 537	1 265	733	749	6 340	7 126
32"	800	781	1 651	1 651	1 667	1 365	783	815	8 227	9 197
34"	850	832	1 778	1 778	1 794	1 460	830	863	9 420	10 260
36"	900	876	1 880	1 880	1 895	1 510	905	892	10 458	11 621
40"	1 000	978	1 900	2 000	-	1 650	943	955	13 210	14 233
42"	1 050	1 022	1 950	2 100	-	1 725	982	1 013	15 200	16 450
44"	1 100	1 075	2 050	2 200	-	1 820	1 030	1 060	17 100	18 150
48"	1 200	1 168	2 180	2 400	-	1 970	1 105	1 135	20 800	22 685
56"	1 400	1 362	2 385	-	-	2 275	1 254	1 290	31 800	-

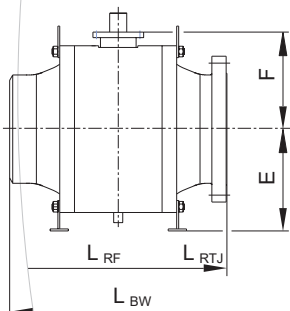

### PN 100 – Class 600

NPS	DN	D	L BW	L RF	L RTJ	Dv	E	F	weight (kg)	
									BW	RF, RTJ
2"	50	49	292	292	295	175	93	125	25	31
3"	80	74	356	356	359	210	113	148	53	78
4"	100	100	432	432	435	245	130	200	71	100
6"	150	152	559	559	562	330	237	249	152	208
8"	200	203	660	660	664	413	277	297	295	378
10"	250	254	787	787	791	488	314	337	420	560
12"	300	305	838	838	841	569	355	378	663	824
14"	350	337	889	889	892	621	381	400	923	1 080
16"	400	387	991	991	994	713	427	448	1 434	1 714
18"	450	438	1 092	1 092	1 095	775	460	492	1 830	2 120
20"	500	489	1 194	1 194	1 200	868	500	538	2 250	2 664
22"	550	540	1 295	1 295	1 305	956	558	583	2 760	3 250
24"	600	591	1 397	1 397	1 407	1 030	615	615	3 550	4 092
26"	650	635	1 448	1 448	1 461	1 080	640	650	4 460	5 150
28"	700	686	1 549	1 549	1 562	1 180	675	690	5 420	5 800
30"	750	737	1 651	1 651	1 664	1 265	733	749	6 450	7 083
32"	800	781	1 778	1 778	1 794	1 365	783	815	8 330	9 137
34"	850	832	1 930	1 930	1 946	1 460	830	863	9 850	11 150
36"	900	876	2 083	2 083	2 099	1 510	905	892	10 690	11 549
40"	1 000	978	1 900	2 000	-	1 650	943	955	13 210	14 355
42"	1 050	1 022	1 950	2 100	-	1 725	982	1 013	15 230	16 975
44"	1 100	1 075	2 050	2 200	-	1 820	1 030	1 060	17 100	18 550
48"	1 200	1 168	2 180	2 400	-	1 970	1 105	1 135	20 800	22 990
56"	1 400	1 362	2 385	-	-	2 275	1 254	1 290	31 800	-

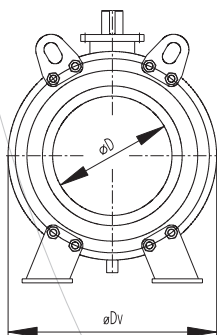

PN 160 – Class 900

NPS	DN	D	L BW	L RF	L RTJ	Dv	E	F	weight (kg)	
									mm	
2"	50	49	368	368	371	190	102	135	40	63
3"	80	74	381	381	384	220	113	148	69	83
4"	100	100	457	457	460	245	130	225	140	157
6"	150	152	610	610	613	335	288	255	230	286
8"	200	203	737	737	740	425	333	295	345	440
10"	250	254	838	838	841	512	376	357	560	720
12"	300	305	965	965	968	598	419	386	770	990
14"	350	324	1 029	1 029	1 038	665	453	420	950	1 220
16"	400	375	1 130	1 130	1 140	734	487	471	1 150	1 610
18"	450	425	1 219	1 219	1 232	808	524	509	2 140	2 600
20"	500	473	1 321	1 321	1 334	889	565	547	2 860	3 480
22"	550	524	1 422	1 422	1 441	980	625	594	3 580	4 350
24"	600	572	1 549	1 549	1 568	1 069	670	644	4 310	5 230
26"	650	619	1 570	1 600	1 622	1 148	709	685	5 180	6 350
28"	700	667	1 600	1 660	1 682	1 222	746	757	6 030	7 370
30"	750	714	1 660	1 760	1 782	1 302	786	798	7 240	8 850
32"	800	762	1 760	1 850	1 872	1 388	829	836	8 470	10 300
34"	850	810	1 850	1 950	1 980	1 475	873	880	10 530	12 770
36"	900	857	1 900	2 050	2 080	1 548	924	918	12 440	15 050
40"	1 000	954	2 100	2 180	-	1 725	1 013	1 007	15 240	18 580
42"	1 050	1 000	2 180	2 250	-	1 750	1 025	1 018	20 065	23 995
44"	1 100	1 048	2 250	2 380	-	1 995	1 048	1 150	21 820	26 170
48"	1 200	1 143	2 380	2 450	-	2 120	1 210	1 212	25 730	31 200

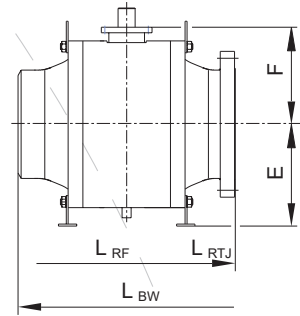

- Approximate weights.
- Fully welded ball valves in diameters NPS 2"-4" (DN 50-100) for pressure CLASS 150 (PN 16) are supplied in wafer design.
- MSA, a.s. supplies fully welded ball valves also for pressure CLASS 2500 (PN 420) in diameters up to NPS 12" (DN 300) - dimensions on request.

PN 250 – Class 1500

NPS	DN	D	L BW	L RF	L RTJ	Dv	E	F	weight (kg)	
									mm	
2"	50	49	368	368	371	190	102	135	52	99
3"	80	74	470	470	473	230	125	158	88	115
4"	100	100	546	546	549	285	152	203	160	180
6"	150	146	705	705	711	425	333	300	330	400
8"	200	194	832	832	841	536	388	350	615	735
10"	250	241	991	991	1 000	652	446	427	925	1 120
12"	300	289	1 130	1 130	1 146	766	503	470	1 300	1 550
14"	350	318	1 257	1 257	1 276	868	569	522	1 600	1 915
16"	400	362	1 384	1 384	1 407	988	629	598	1 950	2 350
18"	450	407	1 537	1 537	1 559	1 090	680	650	2 750	3 300
20"	500	454	1 664	1 664	1 686	1 180	725	692	3 715	4 455
22"	550	500	1 692	1 692	1 721	1 320	785	764	4 625	5 545
24"	600	544	1 943	1 943	1 972	1 415	858	817	5 540	6 660
26"	650	590	2 070	2 070	2 124	1 535	918	878	7 000	8 460
28"	700	635	2 198	2 198	2 251	1 645	973	969	8 020	9 650
30"	750	680	2 300	2 300	-	1 735	1 018	1 015	9 690	11 620
32"	800	725	2 400	2 400	-	1 865	1 083	1 075	11 000	13 220
34"	850	771	2 550	2 550	-	1 980	1 140	1 133	13 500	16 200
36"	900	816	2 700	2 700	-	2 090	1 195	1 190	15 900	18 880

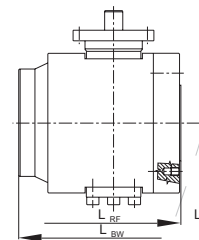
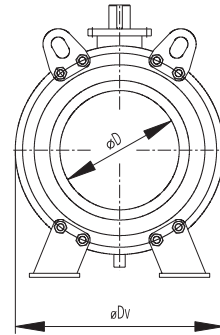

Designed Dimension – Class 2500

NPS	DN	D	L <sub>BW</sub>	L <sub>RF</sub>	L <sub>RTJ</sub>	Dv	M	m	N	E	F	Ød	H	Top Flange ISO 5211	weight (kg)	
															G <sub>BW</sub>	G <sub>RF, RTJ</sub>
2"	50	42	451	451	454	230	146	8	190	175	182	35	45	F14	76	110
3"	80	62	578	578	584	275	220	10	220	195	211	40	50	F16	140	210
4"	100	87	673	673	683	315	190	10	240	210	248	55	70	F16	160	265
6"	150	131	914	914	927	425	406	80	370	355	307	70	90	F25	500	750
8"	200	179	1 022	1 022	1 038	545	480	100	430	400	371	90	110	F30	1 100	1 420
10"	250	223	1 270	1 270	1 292	630	570	100	500	445	430	100	125	F30	1 500	2 185
12"	300	265	1 422	1 422	1 445	750	640	100	600	405	520	120	150	F35	2 015	2 955
14"	350	292	1 480	-	1 630	805	700	100	650	550	570	120	150	F40	3 280	3 690
16"	400	333	1 540	-	1 815	900	760	100	700	600	620	130	165	F40	4 040	5 590
18"	450	374	1 740	-	1 910	1 000	880	180	750	700	675	160	200	F48	5 250	7 200
20"	500	419	1 920	-	2 060	1 180	980	180	800	790	772	180	240	F60	9 615	12 095

# K 83 TB

## Bolted body ball valves

- Water, gas, oil, acid, hydraulic fluid, and hydrogen process medium
- Flanged or welded connection
- Range of working temperatures from -60 °C to +200 °C

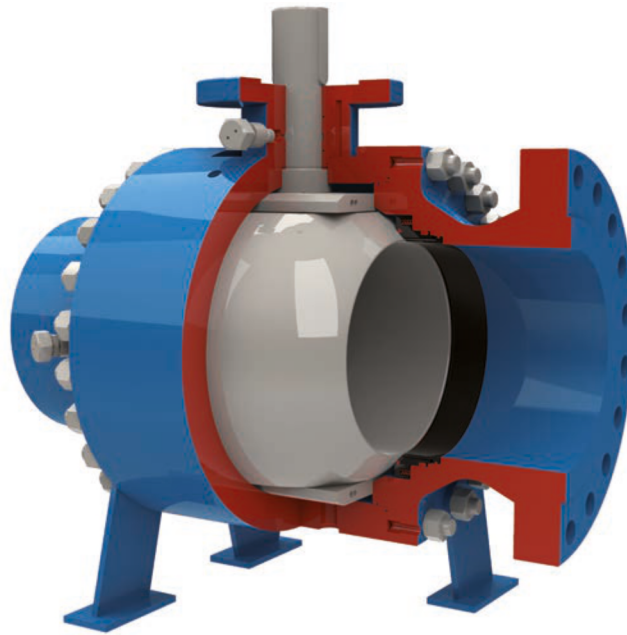

### Standard Material Specification:

	part	standard design from -29 °C to 120 °C	low temperatures from -60 °C to 120 °C	sour working medium according to NACE MR-01-75 from -46 °C to 120 °C	high temperatures from -10 °C to 200 °C
1	body	ASTM A 350 LF2	ASTM A 350 LF2	ASTM A 350 LF2	ASTM A 350 LF2
2	cover	ASTM A 350 LF2, A 694 F52, A 694 F60	ASTM A 350 LF2, A 694 F52, A 694 F60	A 350 LF2, A 694 F52, A 694 F60	ASTM A 350 LF2, A 694 F60
3	ball	ASTM A 350 LF2 + Cr or Ni	ASTM A 350 LF2 + Cr or Ni	ASTM A 350 LF2 + Ni	ASTM A 350 LF2 + Cr or Ni
4	seat	ASTM A 350 LF2 + Ni	ASTM A 350 LF2 + Ni	ASTM A 350 LF2 + Ni or F316	ASTM A350 LF2 + Ni
5	trunnion, stem	ASTM A 350 LF2, AISI 4140 + Ni (Cr)	ASTM A 350 LF2, AISI 4140 + Ni (Cr)	ASTM A 350 LF2 + Ni, A 182 F316	ASTM A 350 LF2, AISI 4140 + Ni (Cr)
6	bolt	ASTM A 193 B7	ASTM A 320 L7 (M)	ASTM A 320 L7M	ASTM A 193 B7
7	nut	ASTM A 194 2H	ASTM A 194 Gr.7 (M)	ASTM A 194 7M	ASTM A 194 2H
8	flange	ASTM A 350LF2, S 355 J2	ASTM A 350LF2, S 355 J2	ASTM A 350LF2, S 355 J2	ASTM A 350LF2, S 355 J2
9	ball gasket	THERBAN, VITON, PTFE, NYLON, DEVLON, PEEK	THERBAN (LOW), PTFE, NYLON, DEVLON, PEEK	VITON, DEVLON, PTFE, NYLON, PEEK	VITON, PTFE, PEEK
10	gasket sealing ring	THERBAN, VITON	THERBAN (LOW)	VITON	VITON
11	KU bushing	CARBON STEEL + PTFE	CARBON STEEL + PTFE	STAINLESS STEEL + PTFE	CARBON STEEL + PTFE
12	axial bearing	CARBON STEEL + PTFE	CARBON STEEL + PTFE	STAINLESS STEEL + PTFE	CARBON STEEL + PTFE
13	gasket ring - fire safe	GRAPHITE	GRAPHITE	GRAPHITE	GRAPHITE
14	seat springs	AISI 302	AISI 302	INCONEL 750	AISI 302

- Other material specifications according to manufacturer's suggestion or customers' requirements.

PN 16 – Class 150

NPS	DN	D	L BW	L RF	L RTJ	Dv	E	F	weight (kg)	
									BW	RF, RTJ
2"	50	49	216	178	191	175	93	118	21	27
3"	80	74	283	203	216	200	108	133	40	45
4"	100	100	305	229	241	240	128	210	58	69
6"	150	152	457	394	406	330	231	245	145	170
8"	200	203	521	457	470	405	277	288	245	270
10"	250	254	559	533	546	479	310	331	320	354
12"	300	305	635	610	622	549	344	368	560	610
14"	350	337	762	686	699	598	370	393	860	925
16"	400	387	838	762	775	688	415	437	1 036	1 206
18"	450	438	914	864	876	760	453	470	1 320	1 540
20"	500	489	991	914	927	842	491	515	1 758	1 832
22"	550	540	1 067	991	1 003	930	545	560	2 150	2 350
24"	600	591	1 143	1 067	1 080	995	598	605	2 860	2 970
26"	650	635	1 245	1 143	-	1 045	622	632	3 420	3 650
28"	700	686	1 346	1 245	-	1 150	675	683	4 250	4 533
30"	750	737	1 397	1 295	-	1 226	713	721	5 000	5 307
32"	800	781	1 524	1 372	-	1 325	763	775	5 640	6 090
34"	850	822	1 626	1 473	-	1 415	808	840	6 420	6 870
36"	900	876	1 727	1 524	-	1 468	834	849	8 040	8 565
40"	1 000	978	1 780	1 850	-	1 616	928	943	10 260	10 872
42"	1 050	1 022	1 840	1 900	-	1 690	965	1 012	13 600	14 500
44"	1 100	1 075	1 900	1 950	-	1 782	1 010	1 026	14 800	15 850
48"	1 200	1 168	2 100	2 180	-	1 922	1 061	1 097	16 800	17 800
56"	1 400	1 362	2 250	2 300	-	2 250	1 232	1 268	25 720	27 205

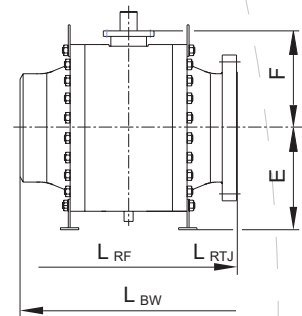

PN 40 (50) – Class 300

NPS	DN	D	L BW	L RF	L RTJ	Dv	E	F	weight (kg)	
									BW	RF, RTJ
2"	50	49	216	216	232	175	93	118	22	28
3"	80	74	283	283	298	210	113	133	41	55
4"	100	100	305	305	321	245	130	225	59	78
6"	150	152	457	403	419	330	231	245	145	178
8"	200	203	521	502	518	405	277	288	245	293
10"	250	254	559	568	584	479	310	331	320	392
12"	300	305	635	648	664	549	344	368	560	660
14"	350	337	762	762	778	598	370	393	860	990
16"	400	387	838	838	854	688	415	437	1 036	1 286
18"	450	438	914	914	930	760	453	470	1 320	1 640
20"	500	489	991	991	1 010	842	491	515	1 758	1 928
22"	550	540	1 092	1 092	1 114	930	545	560	2 190	2 450
24"	600	591	1 143	1 143	1 165	995	598	605	2 860	3 060
26"	650	635	1 245	1 245	1 270	1 045	622	632	3 500	3 820
28"	700	686	1 346	1 346	1 372	1 150	675	683	4 250	4 815
30"	750	737	1 397	1 397	1 422	1 226	713	721	5 000	5 595
32"	800	781	1 524	1 524	1 553	1 325	763	775	5 640	6 430
34"	850	822	1 626	1 626	1 654	1 415	808	840	6 420	7 050
36"	900	876	1 727	1 727	1 756	1 468	834	849	8 040	8 966
40"	1 000	978	1 780	1 850	-	1 616	928	943	10 260	10 890
42"	1 050	1 022	1 840	1 900	-	1 690	965	1 012	13 600	14 500
44"	1 100	1 075	1 900	1 950	-	1 782	1 010	1 026	14 800	16 050
48"	1 200	1 168	2 100	2 180	-	1 922	1 061	1 097	16 800	17 920
56"	1 400	1 362	2 250	2 300	-	2 250	1 232	1 268	25 720	27 310

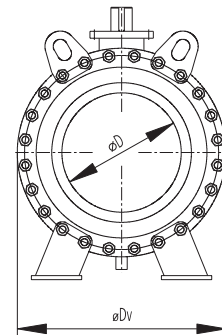

### PN 63 – Class 400

NPS	DN	D	L BW	L RF	L RTJ	Dv	E	F	weight (kg)	
									BW	RF, RTJ
2"	50	49	292	292	295	175	93	125	24	30
3"	80	74	356	356	359	220	113	148	50	68
4"	100	100	406	406	410	245	130	200	64	88
6"	150	152	495	495	498	330	237	249	148	198
8"	200	203	597	597	600	413	277	297	289	362
10"	250	254	673	673	676	488	314	337	404	522
12"	300	305	762	762	765	569	355	378	648	785
14"	350	337	826	826	829	621	381	400	908	1 072
16"	400	387	902	902	905	713	427	448	1 401	1 619
18"	450	438	978	978	981	775	460	492	1 650	1 810
20"	500	489	1 054	1 054	1 060	868	500	538	2 181	2 487
22"	550	540	1 143	1 143	1 153	956	558	583	2 510	2 830
24"	600	591	1 232	1 232	1 241	1 030	615	615	3 436	3 856
26"	650	635	1 308	1 308	1 321	1 080	640	650	3 860	4 320
28"	700	686	1 397	1 397	1 410	1 180	675	690	5 276	5 836
30"	750	737	1 524	1 524	1 537	1 265	733	749	6 340	7 126
32"	800	781	1 651	1 651	1 667	1 365	783	815	8 227	9 197
34"	850	832	1 778	1 778	1 794	1 460	830	863	9 420	10 260
36"	900	876	1 880	1 880	1 895	1 510	905	892	10 458	11 621
40"	1 000	978	1 900	2 000	-	1 650	943	955	13 210	14 233
42"	1 050	1 022	1 950	2 100	-	1 725	982	1 013	15 200	16 450
44"	1 100	1 075	2 050	2 200	-	1 820	1 030	1 060	17 100	18 150
48"	1 200	1 168	2 180	2 400	-	1 970	1 105	1 135	20 800	22 685
56"	1 400	1 362	2 385	-	-	2 275	1 254	1 290	31 800	-

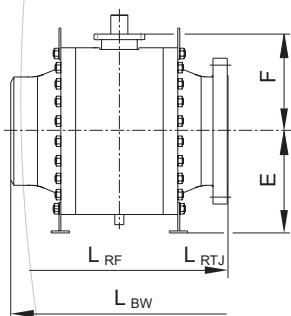

### PN 100 – Class 600

NPS	DN	D	L BW	L RF	L RTJ	Dv	E	F	weight (kg)	
									BW	RF, RTJ
2"	50	49	292	292	295	175	93	125	25	31
3"	80	74	356	356	359	210	113	148	53	78
4"	100	100	432	432	435	245	130	200	71	100
6"	150	152	559	559	562	330	237	249	152	208
8"	200	203	660	660	664	413	277	297	295	378
10"	250	254	787	787	791	488	314	337	420	560
12"	300	305	838	838	841	569	355	378	663	824
14"	350	337	889	889	892	621	381	400	923	1 080
16"	400	387	991	991	994	713	427	448	1 434	1 714
18"	450	438	1 092	1 092	1 095	775	460	492	1 830	2 120
20"	500	489	1 194	1 194	1 200	868	500	538	2 250	2 664
22"	550	540	1 295	1 295	1 305	956	558	583	2 760	3 250
24"	600	591	1 397	1 397	1 407	1 030	615	615	3 550	4 092
26"	650	635	1 448	1 448	1 461	1 080	640	650	4 460	5 150
28"	700	686	1 549	1 549	1 562	1 180	675	690	5 420	5 800
30"	750	737	1 651	1 651	1 664	1 265	733	749	6 450	7 083
32"	800	781	1 778	1 778	1 794	1 365	783	815	8 330	9 137
34"	850	832	1 930	1 930	1 946	1 460	830	863	9 850	11 150
36"	900	876	2 083	2 083	2 099	1 510	905	892	10 690	11 549
40"	1 000	978	1 900	2 000	-	1 650	943	955	13 210	14 355
42"	1 050	1 022	1 950	2 100	-	1 725	982	1 013	15 230	16 975
44"	1 100	1 075	2 050	2 200	-	1 820	1 030	1 060	17 100	18 550
48"	1 200	1 168	2 180	2 400	-	1 970	1 105	1 135	20 800	22 990
56"	1 400	1 362	2 385	-	-	2 275	1 254	1 290	31 800	-

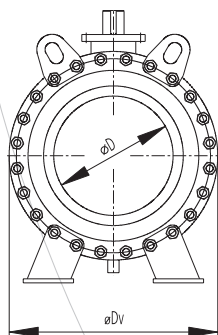

PN 160 – Class 900

NPS	DN	D	L BW	L RF	L RTJ	Dv	E	F	weight (kg)	
									mm	
2"	50	49	368	368	371	190	102	135	40	63
3"	80	74	381	381	384	220	113	148	69	83
4"	100	100	457	457	460	245	130	225	140	157
6"	150	152	610	610	613	335	288	255	230	286
8"	200	203	737	737	740	425	333	295	345	440
10"	250	254	838	838	841	512	376	357	560	720
12"	300	305	965	965	968	598	419	386	770	990
14"	350	324	1 029	1 029	1 038	665	453	420	950	1 220
16"	400	375	1 130	1 130	1 140	734	487	471	1 150	1 610
18"	450	425	1 219	1 219	1 232	808	524	509	2 140	2 600
20"	500	473	1 321	1 321	1 334	889	565	547	2 860	3 480
22"	550	524	1 422	1 422	1 441	980	625	594	3 580	4 350
24"	600	572	1 549	1 549	1 568	1 069	670	644	4 310	5 230
26"	650	619	1 570	1 600	1 622	1 148	709	685	5 180	6 350
28"	700	667	1 600	1 660	1 682	1 222	746	757	6 030	7 370
30"	750	714	1 660	1 760	1 782	1 302	786	798	7 240	8 850
32"	800	762	1 760	1 850	1 872	1 388	829	836	8 470	10 300
34"	850	810	1 850	1 950	1 980	1 475	873	880	10 530	12 770
36"	900	857	1 900	2 050	2 080	1 548	924	918	12 440	15 050
40"	1 000	954	2 100	2 180	-	1 725	1 013	1 007	15 240	18 580
42"	1 050	1 000	2 180	2 250	-	1 750	1 025	1 018	20 065	23 995
44"	1 100	1 048	2 250	2 380	-	1 995	1 048	1 150	21 820	26 170
48"	1 200	1 143	2 380	2 450	-	2 120	1 210	1 212	25 730	31 200

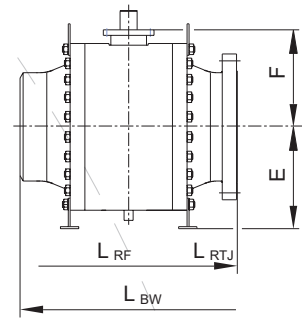

- Approximate weights.
- Bolted ball valves in diameters NPS 2"-4" (DN 50-100) for pressure CLASS 150 (PN 16) are supplied in wafer design.

PN 250 – Class 1500

NPS	DN	D	L BW	L RF	L RTJ	Dv	E	F	weight (kg)	
									mm	
2"	50	49	368	368	371	190	102	135	52	99
3"	80	74	470	470	473	230	125	158	88	115
4"	100	100	546	546	549	285	152	203	160	180
6"	150	146	705	705	711	425	333	300	330	400
8"	200	194	832	832	841	536	388	350	615	735
10"	250	241	991	991	1 000	652	446	427	925	1 120
12"	300	289	1 130	1 130	1 146	766	503	470	1 300	1 550
14"	350	318	1 257	1 257	1 276	868	569	522	1 600	1 915
16"	400	362	1 384	1 384	1 407	988	629	598	1 950	2 350
18"	450	407	1 537	1 537	1 559	1 090	680	650	2 750	3 300
20"	500	454	1 664	1 664	1 686	1 180	725	692	3 715	4 455
22"	550	500	1 692	1 692	1 721	1 320	785	764	4 625	5 545
24"	600	544	1 943	1 943	1 972	1 415	858	817	5 540	6 660
26"	650	590	2 070	2 070	2 124	1 535	918	878	7 000	8 460
28"	700	635	2 198	2 198	2 251	1 645	973	969	8 020	9 650
30"	750	680	2 300	2 300	-	1 735	1 018	1 015	9 690	11 620
32"	800	725	2 400	2 400	-	1 865	1 083	1 075	11 000	13 220
34"	850	771	2 550	2 550	-	1 980	1 140	1 133	13 500	16 200
36"	900	816	2 700	2 700	-	2 090	1 195	1 190	15 900	18 880

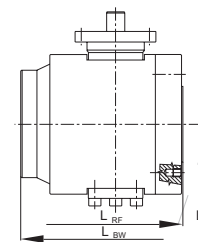
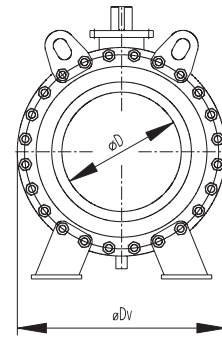

Designed Dimension – Class 2500

NPS	DN	D	L <sub>BW</sub>	L <sub>RF</sub>	L <sub>RTJ</sub>	Dv	M	m	N	E	F	Ød	H	Top Flange ISO 5211	weight (kg)	
															G <sub>BW</sub>	G <sub>RF, RTJ</sub>
2"	50	42	451	451	454	230	146	8	190	175	182	35	45	F14	76	110
3"	80	62	578	578	584	275	220	10	220	195	211	40	50	F16	140	210
4"	100	87	673	673	683	315	190	10	240	210	248	55	70	F16	160	265
6"	150	131	914	914	927	425	406	80	370	355	307	70	90	F25	500	750
8"	200	179	1 022	1 022	1 038	545	480	100	430	400	371	90	110	F30	1 100	1 420
10"	250	223	1 270	1 270	1 292	630	570	100	500	445	430	100	125	F30	1 500	2 185
12"	300	265	1 422	1 422	1 445	750	640	100	600	405	520	120	150	F35	2 015	2 955
14"	350	292	1 480	-	1 630	805	700	100	650	550	570	120	150	F40	3 280	3 690
16"	400	333	1 540	-	1 815	900	760	100	700	600	620	130	165	F40	4 040	5 590
18"	450	374	1 740	-	1 910	1 000	880	180	750	700	675	160	200	F48	5 250	7 200
20"	500	419	1 920	-	2 060	1 180	980	180	800	790	772	180	240	F60	9 615	12 095

# K 83.9

## Metal seated ball valves

- Water, gas, oil, acid, hydraulic fluid, and hydrogen process medium
- For high temperature medium and abrasive medium
- Flanged or welded connection
- hydraulic fluid and hydrogen process medium
- Range of working temperatures from -29 °C to +550 °C
- TB and TW designs

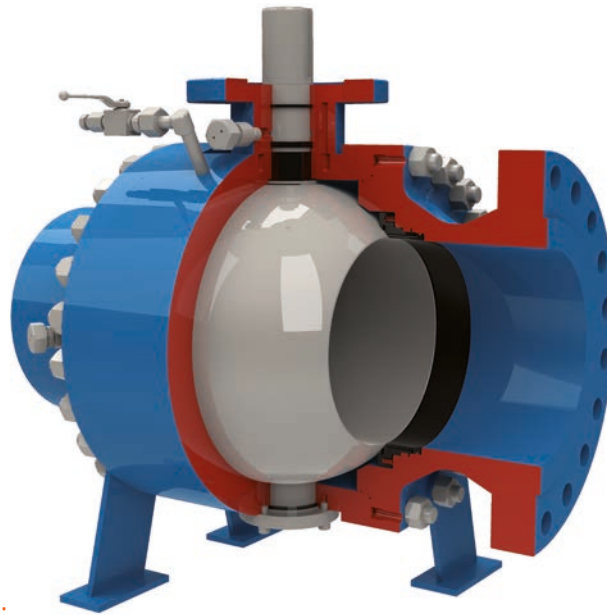

### Standard Material Specification:

	part	design A from -29 °C to 200 °C	design B from 200 °C to 300 °C	design C from 300 °C to 550 °C
1	body	A 350 LF2	A 350 LF2	A 182 F22, F316
2	cover	A 350 LF2	A 350 LF2 (3)	A 182 F22, F316
3	seat	A 350 LF2 + WC (2)	A 182 F6a Cl.2 + WC	A 182 F6a Cl.2 + CrC
4	ball	A 350 LF2 + WC (2)	A 182 F6a Cl.2 + WC	A 182 F6a Cl.2 + CrC
5	trunnion, stem	AISI 4140 + ENP	A 182 F316, 17-4PH	A 182 F316, 17-4PH
6	stud	A 350 LF2 + ENP	A 350 LF2 + ENP	A 182 F22, F316
7	bolt	A 193 B7	A 193 B7	A 193 B8M Cl.2
8	nut	A 194 2H	A 194 2H	A 194 8M
9	flange	S355J2	S355J2	A 182 F316
10	seat sealing	TUNGSTEN CARBIDE	TUNGSTEN CARBIDE	CHROME CARBIDE
11	gasket ring	VITON GLP	VITON GLP	GRAFIT
12	friction bearing	CS + PTFE	SS + PTFE	SS + CrC
13	axial bearing	CS + PTFE	SS + PTFE	SS + CrC
14	gasket ring - fire safe	VITON GLP + GRAPHITE	GRAPHITE	GRAPHITE
15	seat springs	AISI 302	INCONEL 750	INCONEL 750

- Seat pockets in design B are welded with mat. A 182 F316
- Valve tightness for design A is according to ISO5208 st. A, for design B, C according to ANSI FCI class V
- For design B, C valves are provided with stem extension
- For design B, C drain and vent lines are terminated with a gate valve

Standard version (without extension)

PN 16 – Class 150

NPS	DN	D	L BW	L RF	L RTJ	Dv	E	F	weight (kg)	
									mm	
2"	50	49	216	178	191	185	167	143	37	40
3"	80	74	283	203	216	220	190	150	48	57
4"	100	100	305	229	241	255	210	182	70	77
6"	150	150	457	394	406	330	255	235	130	143
10"	250	252	559	533	546	490	398	325	352	384
12"	300	303	635	610	622	560	430	375	572	627
14"	350	334	762	686	699	640	431	422	777	819
16"	400	385	838	762	775	705	500	465	941	1 070
18"	450	436	914	864	876	775	545	481	1 251	1 330
20"	500	487	914	914	927	860	634,5	543	1 677	1 760
24" - 40"	Upon request									

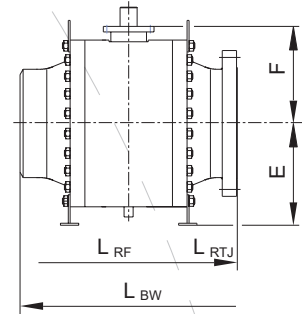

PN 40 (50) – Class 300

NPS	DN	D	L BW	L RF	L RTJ	Dv	E	F	weight (kg)	
									mm	
2"	50	49	216	232	185	167	167	143	41	48
3"	80	74	283	298	220	190	190	150	72	79
4"	100	100	305	321	255	220	210	182	99	106
6"	150	150	457	403	419	330	255	235	130	164
10"	250	252	559	568	584	490	398	325	352	428
12"	300	303	648	648	664	572	436	380	648	752
14"	350	334	762	762	778	640	431	422	777	954
16"	400	385	838	838	854	725	515	475	1 159	1 354
20"	500	487	991	991	1 010	885	634,5	553	1 960	2 276
22"	600	589	1 143	1 143	1 165	1 035	690	630	2 998	3 390
24" - 40"	Upon request									

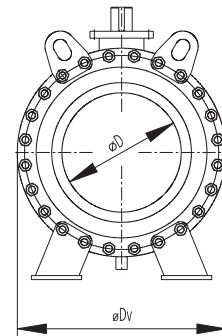

PN 100 – Class 600

NPS	DN	D	L BW	L RF	L RTJ	Dv	E	F	weight (kg)	
									mm	
2"	50	49	292	292	295	185	167	143	33	44
3"	80	74	356	356	359	220	190	150	54	76
4"	100	100	432	432	435	255	210	182	81	112
6"	150	150	559	559	562	333	256	263	165	227
8"	200	201	660	660	664	420	360	297	302	399
12"	300	303	838	838	841	580	440	381	773	949
14"	350	334	889	889	892	655	431	424	963	1 175
16"	400	385	991	991	994	750	535	485	1 455	1 743
20"	500	487	1 194	1 194	1 200	905	644,5	561	2 061	2 496
24" - 40"	Upon request									

PN 160 – Class 900

NPS	DN	D	L BW	L RF	L RTJ	Dv	E	F	weight (kg)	
									mm	
2" - 20"	Upon request									

- As for other diameters - on request (also for ball valves with extension - dedicated for high temperatures).

# K 83.8

## Cryogenic ball valves

- For liquefied gas medium
- Flanged or welded connection
- Range of working temperatures from -30 °C to -196 °C

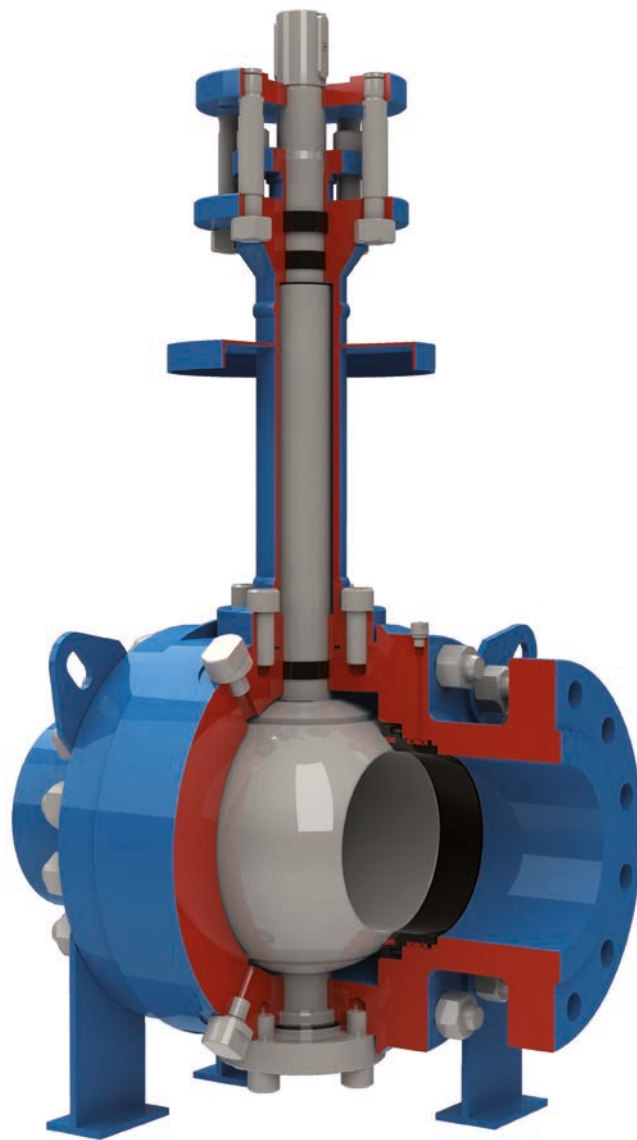

Standard Material Specification:

	part	design A from -30 °C to -46 °C	design B from -47 °C to -104 °C	design C from -105 °C to -196 °C
1	body	A 350 LF2	A 182 F304, 316	A 182 F304, 316
2	cover	A 350 LF2	A 182 F304, 316	A 182 F304, 316
3	seat	A 350 LF2 + 50Ni	A 182 F304, 316	A 182 F304, 316
4	ball	A 350 LF2 + 50Ni	A 182 F304, 316	A 182 F304, 316
5	trunnion, stem	A 182 F6a, AISI 4140+50Ni	A 182 F304, 316	A 182 F304, 316
6	bolt	A 320 L7	A 193 B8M CL2	A 193 B8M CL2
7	nut	A 194 4	A 194 8M	A 194 8M
8	extension	A 350 LF2, S355J2	A 182 F304, 316	A 182 F304, 316
9	flange	A 350 LF2	A 182 F304, 316	A 182 F316
10	ball sealing	RPTFE	RPTFE	PCTFE (KEL-F)
11	seat sealing	"O" ring HNBR	PTFE + ELGILOY	PTFE + ELGILOY
12	gasket ring	"O" ring HNBR	GRAPHITE	GRAPHITE
13	stem seal	"O" ring HNBR	GRAPHITE	GRAPHITE
14	seat springs	AISI 302	INCONEL 750	INCONEL 750

design	working temperature	NPS	CLASS	flow direction
A	from -30 °C to -46 °C	2"-30"	150-900	Bi-directional
B	from -47 °C to -104 °C	2"-20"	150-900	Bi-directional
C	from -105 °C to -196 °C	2"-12"	150-900	UNI-directional

- MSA, a.s. supplies cryogenic ball valves in pressure classes CLASS 150-900 (PN 16-160) in diameters NPS 2"-30" (DN 50-750) - dimensions on request.



# References

---

- Australia
- Austria
- Belgium
- Bulgaria
- Canada
- Croatia
- Czech Republic
- Denmark
- Egypt
- Estonia
- Finland
- France
- Germany
- Great Britain
- Greece
- Hungary
- China
- India
- Indonesia
- Italy
- Japan
- Kazakhstan
- Latvia
- Lithuania
- Netherlands
- Norway
- Pakistan
- Panama
- Poland
- Portugal
- Romania
- Russia
- Saudi Arabia
- Serbia
- Singapur
- Slovakia
- South Korea
- Spain
- Sweden
- Thailand
- Turkey
- U.A.E.
- Ukraine
- USA
- Uzbekistan







[www.msa.cz](http://www.msa.cz)

MSA, a.s.  
Hlučinská 641, 747 22 Dolní Benešov, Czech Republic  
Phone: +420 553 881 111, E-mail: [sales@msa.cz](mailto:sales@msa.cz)